



GAME CHARACTERISTICS

Footvolley is a team sport pitting two teams of two players each, playing on a sand field. A net separates the field in half. A player plays the ball by using any part of his/her body except for the arms and hands. The objective of the game is to send the ball over the net and ground it on the other side, while protecting your own half of the field.

How to play: The game starts with a serve from the serving team by kicking the ball once from the ground. The ball must pass the net for the serve to be playable. The point continues until the ball is grounded, either in the playing field or out of the playing field, or if a team is unable to legally send the ball over the net. A team has a maximum of three touches and no player may touch the ball consecutively (except for an unintentional deflection). Points are scored through the rally point system. A score of one is given to the team who wins the points and that team gets to serve for the next point.

PART 1 THE GAME

SECTION 1: FACILITIES AND EQUIPMENT

RULE SECTION 1: PLAYING AREA

The playing court and free zone (area outside of the playing court)

1.1 DIMENSIONS

- 1.1.1** The playing court is rectangular, measuring 18 meters wide and 9 meters long. The free zone must at least be three meters wide
- 1.1.2** As for matches sanctioned by the International Federation Footvolley (FIFV) the playing court is rectangular, measuring 18 meters wide and 9 meters long. The area between the end lines and the free zone must be at least 5 meters.

1.2 PLAYING SURFACE

- 1.2.1** The surface must be leveled and even sand, both inside and outside the boundary lines. It must be free of rocks, sea shells, and other debris that may injure a player.



- 1.2.2 As for matches sanctioned by the International Federation Footvolley (FIFV), the sand must have a thickness of at least 40 cm.
- 1.2.3 The playing surface must not pose any injury threats to the players
- 1.2.4 As for international matches, the sand must be raked so that it achieves a fine and level surface, but must not result in the area being filled with dust. The surface must be free of any sort of sediments and any other material that may injure a player.
- 1.2.5 As for international matches, if rain persists, a cloth may be used to cover the entire playing field.

1.3 BOUNDARY LINES

- 1.3.1 There are two side boundary lines and two end boundary lines.
- 1.3.2 There are no boundary lines separating the field in half
- 1.3.3 All boundary lines are to be 5 – 8 centimeters wide
- 1.3.4 All boundary lines are to be of the same color and must be clearly visible against the sand.
- 1.3.5 The boundary lines are to be made of stern and stretchable ribbons or similar material.

1.4 SERVICE ZONE

The service zone is any area behind the end lines, starting from where the by-lines and end lines meet extended. It could be as far back as the free zone allows.

1.5 WEATHER

The weather must not disrupt the flow of the game or pose injury threats to anybody.

1.6 LIGHTING

For international matches taking place at night, the lights must measure between 1,000 – 1,500 lux. The officiating and technical crew are to check for the safety of the lights before the start of the match.



RULE SECTION 2: NET AND POSTS

2.1 NET

The net is 9.5 meters long and 1 meter wide (3 centimeters shorter or longer is acceptable), with square meshes of 10 cm. The lateral strip on the top and bottom of the net should measure 5-8 centimeters in height and be placed vertically, and may have advertisements.

2.2 SIDE BANDS

The vertical strip on the two sides of the net. It is 5-8 centimeters wide. It is 1 meter wide. Advertisements are allowed.

2.3 ANTENNAS

The antennas are to be 1.8 meters high and 10 millimeters in diameter and to be made of fiber glass or of similar material. The two antennas are to be placed 80 centimeters from the two extreme ends of the net. They are to be red and white in color. The antennas are to be a part of the net and used for judging if the ball has legally crossed the net or not. (PICTURE 3 SECTION 14.1.1)

2.4 HEIGHT OF THE NET

The net should measure 2.20 meters (2.00 meters for women's matches)

2.5 POSTS

The posts must be stable and straight and 2.55 meters high. The posts must be placed between 0.5-1.00 meters away from the boundary lines.

RULE SECTION 3: THE BALL

3.1 CHARACTERISTICS

The ball must be a mandatory No.5 (No.4 for women) and made of leather or any elastic material that does not absorb water.

Weight 410 – 440 GRAMS

Stitching 68 – 70 centimeters

Pressure 0.56 – 0.63 Kilograms / cm Squared



3.2 UNIFORMITY OF BALLS

All balls used in a match must be identical, including color, weight, air pressure, and stitching.

3.3 THREE BALL SYSTEM

A match must have at least three balls and ball boys positioned at opposite corners of the playing field and behind the each referee.

CHAPTER 2 (PARTICIPANTS)

RULE SECTION 4: TEAMS

4.1 COMPOSITION AND REGISTRATION

4.1.1 Teams register with only two players

4.1.2 The two players who register are the only players allowed to play in the match.

4.2 CAPTAIN

A team must consist of one captain

RULE SECTION 5: PLAYERS UNIFORMS

5.1 UNIFORM

5.1.1 The uniforms of a player consists of a shirt and shorts or swimming trunks.

5.1.2 For international matches, uniforms of players must match his/her team mate.

5.1.3 The uniforms must be clean

5.1.4 Players are not permitted to wear foot accessories, for example, ankle support, except with the referee's permission.

5.1.5 Uniforms must have the numbers 1 and 2 either on the front or back of the shirt or on the pants.

5.1.6 The numbers must be of a contrasting color from the uniform and with a height of at least 10 cm and a thickness of at least 1.5 cm

5.2 AUTHORIZED CHANGES

5.2.1 If both teams end up having shirts of the same color, the referee may authorize a change of shirts for either team



5.2.2 Referee #1 can authorize one or all players to:

- A) Wear shoes, socks, or ankle support
- B) Change from wet or damp uniforms between sets

5.2.3 If a player persists, referee #1 may authorize a player to wear another shirt or warm-up uniforms.

5.3 FORBIDDEN OBJECTS AND UNIFORM

5.3.1 Nothing should be worn that can be a cause for injury such as belts, ear rings, etc.

5.3.2 Players are allowed to wear sun glasses, but are responsible for any cause of injury that may occur regarding eye wear.

5.3.3 A player can not wear any unauthorized number. (Rule 5.1.5 and 5.1.6)

PLAYING FORMAT

RULE SECTION 6: RIGHTS AND RESPONSIBILITIES OF THE PARTICIPANTS

6.1 BOTH PLAYERS

6.1.1 All players must learn and accept all rules and regulations before playing.

6.1.2 All players must accept every referee's calls and judgments without any complaints; however, players may enquire the referee about any call.

6.1.3 All participants must treat all players, coaching staff, technical crew, officiating crew, and the audience with respect and sportsmanship

6.1.4 All players may not pressure the referee in changing his/her call.

6.1.5 All players must not waste time during a match.

6.1.6 Players of the same team may communicate to each other during the game.

6.1.7 During a match and after the rally has been ruled dead, players may converse with the officiating crew.

(Rule 6.1.2) In these three contexts

Interactions with the referee



- A) If any player is not satisfied with the performance of the referee, he/she may complain about it in the score sheet after the match.
- B) Permission for
- Change of uniform or accessories
 - Enquire about whose turn it is to serve
 - Questions about the net, ball, and playing surface
 - Re-adjusting the boundary lines so that they are straight
- C) Call for a time-out (Rule 19)

The players may leave the playing field after the referee authorizes the time out.

6.1.8 After the match concludes

- A) All players must be a good sportsman and show appreciation to opposition players and referees
- B) If a players feels referee #1 made an error during a match, he/she may report it by mentioning it on the score sheet. (Rule 6.1.7)

6.2 CAPTAIN

6.2.1 Before the start of the match, the captain must:

- A) Register his/her team before the start of the match
- B) Represent the team during the coin toss.

6.2.2 At the end of the game, the captain verifies the result by signing the score sheet.

6.3 LOCATION OF PARTICIPANT

Athlete's chairs are positioned at least five meters from the end line and at least three meters from the officials' table

RULE SECTION 7: POINT SET AND MATCH WINNER

RULE 7 SCORING SYSTEM

7.1 TO WIN THE MATCH

- 7.1.1 TYPE A:** A single set match. Whoever wins the set wins the match.



7.1.2 TYPE B: A match consisting of a best of three sets. Whichever team wins two sets wins the match.

7.2 TO WIN THE SET

7.2.1 TYPE A: (Rule 7.1.1) The winning team is the first team to reach 18 points. If the score is tied at 17, the winning is decided if a team scores two consecutive points (19:17, 20:18) or if necessary (after a 20:20 tie), whichever team reaches 21 points.

7.2.2 TYPE B: (Rule 7.1.2) whichever team reaches 18 points in a set first, wins the set. If the score is tied at 17, the winner is decided if a team scores two consecutive points (19:17, 20:18) or if necessary (after a 20:20 tie), whichever team reaches 21 points. If teams are tied at one set apiece, the match goes to a deciding third set, with the winners the first to reach 15 points. If teams are tied at 14 points, the winner is decided if a team scores two consecutive points (16:14, 17:15) or if necessary, 17 points wins the match after a 16:16 tie.

7.3 TO WIN A RALLY

A team that wins a rally earns 1 point (Rule 7.2.1, 7.2.2) At any point during a set, when both teams' scores are divisible by 6 (6, 12, 18, 24, 30, 36), then, the teams change sides

CHAPTER 4 STRUCTURE OF PLAY

RULE SECTION 8: PREPARATION OF THE MATCH

8.1 COIN TOSS

Before the start of the match, the referee will call each team's captain for the coin toss. The winner of the coin toss may choose to A) serve or B) choose a side. The loser of the coin toss gets the reverse result of the coin toss for the second set. If the match goes to a third set, the coin toss would be conducted again.

8.2 WARM UP SESSION

Before a match, if a playing field is available, athletes may warm up for five minutes elsewhere.



RULE SECTION 9: TEAM LINE – UP

- 9.1 The two athletes from each team must be on the playing field at all times.
- 9.2 Substitutions are not permitted during a match.

RULE SECTION 10: PLAYER'S POSITIONS

10.1 POSITIONS

- 10.1.1 During a serve, all players must be within the boundary lines (except for the server)
- 10.1.2 A player may position him/herself anywhere on the field inside the boundary lines during a serve.
- 10.1.3 There are no illegal positions for any player.

10.2 SERVICE ORDER

A service order (player #1, player#2, player #1, player#2, etc.) must be kept throughout the set (the captain tells the order to the referee after the coin toss)

10.3 SERVICE ORDER FAULT

- 10.3.1 After player #1 serves, player#2 on the same team serve for the team for the next time. This order is maintained through out the match.
- 10.3.2 The scorekeeper informs everyone about the service order and corrects all inquiries about the service order.
- 10.3.3 A service order mistake. It would be considered illegal within the rules, and the opposing team would be rewarded one point. (Rule 12.2.1)

CHAPTER 5 PLAYING ACTION

RULE SECTION 11: STATES OF PLAY

11.1 BALL IN PLAY

The start of play begins with the referee's whistle and the ball is in play after the serve.



11.2 BALL OUT OF PLAY

The referee will blow his/her whistle when he/her sees a fault within the rally and the play stops.

11.3 (BALL IN)

The ball is considered in bounds if it hits any area in the playing field, including any part of the boundary lines. (Rule 1.3)

11.4 (BALL OUT)

The ball is considered out of bounds if

- A) The ball lands anywhere outside of the playing field
- B) If it hits any object outside of the playing field or people other than the athletes
- C) If the ball hits the post or antenna or the strings connecting the two.
- D) If the ball curls around the post, and antenna, or the strings connecting the two. (Rule 14.1.2, 14.1.3)

RULE SECTION 12: PLAYING FAULTS

12.1 DEFINITION

12.1.1 If any occurrences occur outside of the rules stated in this draft, it is considered a fault.

12.1.2 The officiating crew will judge and faults and impose any punishment they seem fit.

12.2 CONSEQUENCES OF FAULT

12.2.1 A penalty will be imposed for every fault.

12.2.2 If two or more mistakes are made successively, then the first one is considered.

12.2.3 If both teams make a fault at the same time, then the point is replayed.

RULE SECTION 13: PLAYING THE BALL

13.1 TEAM HITS

13.1.1 A team is permitted a maximum of three touches before sending the ball over the net and to the opposition half



13.1.2 A touch is counted towards a team, even though it may be an accidental touch.

13.1.3 A player is not allowed to play the ball consecutively, except after a deflection. (Rule 18.2)

13.2 SIMULTANEOUS CONTACTS

13.2.1 Both players may touch the ball simultaneously

13.2.2 If two players on the same team touches the ball at the same time, then, it is considered two touches for the team. If both players chase a ball, but only one of them gets a touch, then, it is considered one touch for the team. If the players crash into each other, the play continues. (Rule 18.4.2)

13.2.3 If a team touches the ball simultaneously over the net and sends it over to the other half, then the opposition team continues to play with their allotted three touches. If a team touches the ball simultaneously and it goes out of bounds in the opposition half, then the team that sends the ball loses the rally.

13.3 ASSISTED HIT

A player may not use his/her team or other objects as leverage to reach the ball. If a player is about to be impeded in the opposition half, the other player may then pull that player back and avoid a playing fault.

13.4 CHARACTERISTICS OF THE HIT

13.4.1 A ball may touch any part of the body (except for the hands and arms)

13.4.2 Using another player to get to a ball.

13.5 FAULT AT PLAYING THE BALL

13.5.1 (four hit) A team touching the ball four times before sending the ball over the net to the other side (Rule 13.1.1)

13.5.2 ASSISTED HIT

A player uses his/her team mates or other objects as leverage for a hit (Rule 13.3)

13.5.3 HELD BALL

When the ball hits the arm, forearm, or hand. (Rule 13.4.2)

13.5.4 DOUBLE CONTACT



A player who touches the ball consecutively
(Rule 13.1.3 and 13.4.3)

RULE SECTION 14: BALL AT THE NET

14.1 BALL CROSSING THE NET

14.1.1 The ball must cross over the net. It should be in the area between vertical plane of the net, which is defined like this:

- A) The lowest part of the net and the posts that support the net.
- B) The posts that support the net

14.1.2 The ball crossing over the net from outside the playing area and ends up inside the playing area in the opposition half would count as out of bounds.

14.1.3 The ball crossing below the net is considered a point gained for the opposition.

14.1.4 The player trying to prevent the ball from passing under the net is considered a point for the other team. (Rule 15.2)

14.2 BALL TOUCHING THE NET

A ball that touches any part of the net while on its way to the other side. The play continues on.

(Rule 14.1.1)

14.3 BALL IN THE NET

14.3.1 If a ball touches the net, the ball is still deemed playable, with three touches for the receiving team.

14.3.2 If the ball creates a hole or breaks the net, the play is stopped and the point is replayed.

RULE SECTION 15: PLAYER AT THE NET

A player must be at his/her half of the field at all times, although he/she may play the ball from the free zone into the opposition half.

15.1 REACHING BEYOND THE NET

While playing the ball, a player may end up on the opposite side of net as result of his/her momentum. This is not a violation, if the player hasn't touched any part of the net. (Rule 18.3)



15.2 PENETRATION INTO THE OPPONENT SPACE COURT AND/OR FREE ZONE

A player may cross into the opposition's half (either in the playing field or out), if the player's momentum carries him/her and does not interfere with the other team's play.

15.3 CONTACT WITH THE NET

15.3.1 Purposeful contact with any part of the net or antenna is not allowed.

15.3.2 After a player plays the ball outside of the boundary line, that player may accidentally come in contact with the net, antenna, or posts. The play continues if that action does not interfere with the flow of the game.

15.3.3 If the ball comes in contact with the net and the net hits the opposition player, it is not considered a violation.

15.4 PLAYER'S FAULT AT THE NET

15.4.1 Any part of the body that goes over the plane of the net. (Rule 15.1.1)

15.4.2 A player ventures into the opposition half, including from the free zone. (Rule 15.2)

15.4.3 A player touches the net. (Rule 15.3.1)

RULE SECTION 16: SERVICE

16.1 DEFINITION

A serve is the method used to start the point by putting the ball in play, with the server kicking the ball from the ground to the opposition half.

16.2 FIRST SERVICE IN A SET

If team A starts the serve in the first set, then team B starts the serve for the second set. (Rule 8.1)

16.3 SERVICE ORDER

The service order during a match:

- A) After the service team wins the point, that player continues to serve for the next point.



- B) After the opposition team breaks the service team's serve by scoring, that team starts the next point with their serve. The player that hasn't served the point before will serve the ball when that team's turn to serve has arrived.

16.4 AUTHORIZATION OF THE SERVICE

Referee #1 has the authority to start the serve after he/she sees that the ball has been placed behind the end line and that the receiving team is ready.

16.5 EXECUTION OF THE SERVICE

16.5.1 The server may do what he/she wishes to the sand before placing the ball on it for a serve. The server may serve the ball anywhere in the service zone. The server's foot can not be anywhere inside the playing field.

16.5.2 If the sand or wind moves the boundary line, then no fault is called.

16.5.3 The server has five seconds to serve the ball after the referee's whistle and signal to serve

16.5.4 If a serve occurs before the referee's signal, then serve is restarted.

16.5.5 A player may build a dune anywhere in the service zone and place the ball on it for the serve.

16.5.6 A serve is considered a serve after the foot strikes the ball, even though it may be unintentional.

16.5.7 A player may not fake a serve. He/she must strike the ball with the first motion of the kicking leg.

16.6 SCREENING

A player is not allowed to block the oppositions' view of the ball when the serve is about to be executed.

16.7 SERVICE FAULTS

The following are service faults:

- A) Player #1 (for example) continues to serve after his/her turn (Rule 16.3)
- B) Service fouls (Rule 16.5)



16.8 SERVICE FAULTS AFTER HITTING THE BALL

The serve is deemed playable unless:

- A) The ball hits the serving team's other player, or if the ball does not make it through to the opposition half.
- B) The ball goes out of bounds. (Rule 11.4)

RULE SECTION 17: ATTACK HIT

17.1 DEFINITION

17.1.1 Any touch of the ball by a player, with the ball crossing over the net and into the opposition half.

17.1.2 The attack is completed once the ball completely crosses the plane of the net.

17.1.3 A player may rise as high as he /she wishes to attack the ball, but must do so in his/her half of the playing field.

17.2 ATTACK HIT FAULTS

17.2.1 A player strikes the ball in the opposition half. (Rule 15.1.2)

17.2.2 The player strikes the ball and it lands outside of the boundary lines. (Rule 11.4)

RULE SECTION 18: BLOCK

18.1 DEFINITION

A defensive touch with intention of preventing the ball from crossing into the other side.

18.2 HIT BY BLOCKER

First contact with the ball

18.3 BLOCK WITHIN THE OPPONENT'S SPACE

After a block hit, the foot may go beyond the plane of the net if it does not disrupt the opposition's attempt at playing the ball.

18.4 BLOCKING CONTACT

18.4.1 A block is considered one touch, thus, two touches are permitted after the block.



18.4.2 If a player from Team A attacks the ball, and a player from Team B blocks it and the ball goes into Team A's half, Team A can play the ball with, with three touches for the team being reset.

18.4.3 Any part of the body may be used for a block (except for the hands and arms).

18.5 BLOCK FAULTS

A player can not attempt the block before the attack from the other team.

SECTION 6 TIME OUT AND DELAYS

RULE SECTION 19: TIME OUT

19.1 DEFINITION

A time out is a break during a game called by either team, with duration of 60 seconds.

19.2 NUMBER OF TIME OUTS

A team is permitted two time outs per set.

19.3 REQUEST FOR TIMEOUTS

A team may called a time out when the ball is not in play and before the referee blows his/her whistle and signaling that the serve proceeds (Picture 7 Picture 4)

19.4 IMPROPER REQUESTS

A time out is not allowed:

- A) When the ball is still in play or when the referee signals the start of a serve.
- B) Calling one timeout more than the amount allocated to the team per set. (Rule 19.2) (Rule 20.1)

RULE SECTION 20: DELAYS TO THE GAME

20.1 TYPES OF DELAY

Any delay of game is considered rude behavior and is considered when:



- A) Delaying entrance to the playing field after the referee's orders to commence play.
- B) Calling more timeouts than the amount allocated to the team (Rule 19.4)
- C) Time wasting during a match.

20.2 SANCTION FOR A DELAY

20.2.1 The first delay of game will be a warning.

20.2.2 The second and subsequent delay of games will result in a delay penalty and the opposition gaining a point.

RULE SECTION 21: EXCEPTIONAL GAME DELAYS

21.1 INJURY

21.1.1 If an accident occurs resulting in an injury, the referee will stop the match immediately and replay the point.

21.1.2 An injured player may receive treatment for up to five minutes per set. The referee is the only person who has the right to allow treatment to an injured player. The referee can allow the medical staff to enter the playing field and treat the injured player, or may allow the injured player to leave the playing field and receive treatment. The referee will blow his whistle to resume play, and only the injured player can inform the referee if he/she can continue. If after five minutes the injured player can not continue, then the team forfeits the game, and the technical team will make the decision if he/she can continue play or not in later games. (Rule 7.4.3 and Rule 9.1)

The timing starts when the referee allows the medical team to examine the injured player.

21.2 EXTERNAL INTERFERENCE

If so happens that outside interference disrupts the game, the game will stop and will continue replaying that point.

21.3 PROLONGED INTERFERENCE

If any unexpected interference occurs and does not allow the game to continue, then the referee #1 or any event staff may call an end to the game.



21.3.1 If one interruption lasts for less than four hours, then the game resumes from the same score before the interruption.

21.3.2 If there is one interruption lasting four hours or more, the game will restart from the beginning.

RULE SECTION 22: COURT SWITCHES AND INTERVALS

22.1 COURT SWITCHES

Both teams change sides after the scores of both team add up and is divisible by six.

22.2 INTERVALS

22.2.1 Intervals are given after the completion of a (matches of more than one set) with a 5 minute period. If the match goes to a 3rd set, the coin toss will occur after that interval.

(Rule 18.1)

22.2.2 When teams change sides, they are allowed a 30 second rest period. This only occurs with matches having more than one set.

(Rule 22.1) In singles set matches, there are no rest periods between sets. (Rule 7.1.3)

22.2.3 If any officiating crew forgets to authorize a change of sides scores divisible by six, but remembers if after, then, teams do change sides, with the score divisible by six still being a factor of changing sides.

SECTION 7 (MISCONDUCT)

RULE SECTION 23: RULE MISCONDUCT

Any form of behavior that is considered unacceptable to any other player, officiating crew, or audience member.

23.1 CATEGORIES

23.1.1 Showing a lack of sportsmanship, for example, arguing and/or raising one's voice over a disagreement, etc.

23.1.2 Displaying rude behavior and looking down upon any of the athletes, officiating crew, or audience member.



23.1.3 Opposing the referee's call and insult and disrespecting the referee

23.1.4 Displaying aggressive behavior and deliberately hurting someone else.

23.2 SANCTIONS

Punishment will be imposed to athletes displaying poor behavior. Referee #1 will impose punishment (s) as he/she sees fit, and will be note it for further matches.

23.2.1 MISCONDUCT WARNING

Is issued when a player displays unsportsmanlike behavior.

23.2.2 MISCONDUCT PENALTY

Is issued when a player displays rude or unsportsmanlike behavior. The whole team is penalized and the opposing team gains a point.

23.2.3 EXPULSION

Is issued after subsequent warnings and penalties. The player is forced to leave and the team forfeits the game

23.3 SANCTION SCALE

The repetition of rude behavior by a single player is punishable through the scale of sanctions. A player can be punished by more than a red card.

23.4 Any rude behavior during the interval of sets

MISCONDUCT BEFORE AND BETWEEN SETS

Any inappropriate behavior before the match and in between sets. It can have an effect on the following set, according to the referee's call.

PART 2: THE REFEREES, THEIR RESPONSIBILITIES, AND OFFICIAL SIGNALS

CHAPTER 8 (REFEREES)

RULE SECTION 24: REFEREEING CORPS AND PROCEDURES

24.1 COMPOSITION

All matches will compose of these officiating crew

- Referee #1
- Referee #2



- Scorekeeper
- 4 linesmen (or 2 linesmen) each have individual positions (Picture #6)

24.2 PROCEDURES

24.2.1 Only referee #1 and referee #2 are allowed to use whistles during a match

- A) Referee #1 gives the signal for the serve.
- B) The call goes forward if both referee blows the whistle and agrees on the same call.

24.2.2 The referee's whistle confirms any call or action on the the playing field.

24.2.3 The referee blows the whistle and give a hand signal for: (Rule 29.1)

- A) Which team gets to serve
- B) Any fault during the match (if the referee needs to clear up any confusion in service order)
- C) Any player faults during the match (if the referee needs to clear up any confusion)

RULE SECTION 25: REFEREE #1

25.1 LOCATION

Referee #1 is situated on either end of the net and on an elevated chair, positioned 50 centimeters from the net.

25.2 AUTHORITY

25.2.1 Referee #1 must officiate the match from start to finish, and is the leader of the officiating team. Referee #1's call overrules all other officiating crew's conflicting calls. Referee #1 may also authorize a change of officiating personnel he/she may see fit.

25.2.2 Referee #1 can order the ball boys to bring the ball (s) to one half of the playing field as he sees fit

25.2.3 Referee #1 has the final say of every matter befoe, during, and after the match.

25.2.4 Referee #1 can explain to the palyer about any enquiries they may have during the match.



(Rule 6.1.7) Players may complain about the referee and record it on the score sheet.

25.2.5 Referee #1 is holds the responsibility of all proceedings in the stadium and in its vicinity.

25.3 RESPONSIBILITIES

25.3.1 Before the match, referee #1 must:

- A) Check that the playing field, the ball, and all other equipments are up to standard.
- B) Responsible for the coin toss with the respective team captains.
- C) Make sure that each team warms up before the match.

25.3.2 During a match, only referee #1 has the authority to

- A) Punish those whom he sees fit
- B) Officiate in the area of
 - Any faults the server might perform
 - Any screening a player might do to block the view of the serve for the opposing team
 - Any faults a player might perform when playing a ball
 - Any faults regarding the net

RULE SECTION 26: REFEREE #2

26.1 LOCATION

Referee #2 is situated on the opposite side, across the playing field of referee #1.

26.2 AUTHORITY

26.2.1 Referee #2 is the assistant for referee #1 and has his/her own position on the field. Referee #2 has the responsibilities of Referee #1 if Referee #1 can not make a call. (Rule 26.3)

26.2.2 Referee #2 will use hand signals to tell the situation on the field (ball in bounds or out of bounds, etc.), but not use the whistle.

26.2.3 Referee #2 may clear and understanding that the scorekeeper may have.

26.2.4 Referee #2 may allow timeouts for any team requesting one.

26.2.5 Referee #2 will also charge the timeout for the team after the team uses it.



26.2.6 Referee #2 will keep time for the incident involving an injured player. (Rule 21.1.2)

26.2.7 Referee #2 will also inspect the balls before and during the match.

26.3 RESPONSIBILITIES

26.3.1 Referee #2 can use the whistle if

- A) If a player touches the lower portion of the net and the antenna that is on the same side as referee #2 (Rule 15.3.1)
- B) If a player touches the opposing team's player under the net (a foul will be called and a point is awarded to the opposing team. (Rule 15.2)
- C) If the ball touches the antenna or if the ball curls around the antenna (Rule 11.4)
- D) If the ball touches anything outside of the playing field (Rule 11.4)

RULE SECTION 27: SCOREKEEPER

27.1 LOCATION

The scorekeeper is positioned in front of the scoreboard and faces referee #1.

27.2 RESPONSIBILITIES

To correctly keep score and provide assistance to referee #2.

27.2.1 The scorekeeper will fill out the score sheet with all necessary information before the start of the match, and let the team captains sign the sheet.

27.2.2 During a match, the scorekeeper must:

- A) Keep score during the match and make sure the score is accurate
- B) Keep record of the service order
- C) Display the service order with a sign indicating the player's number that has to serve
- D) Keep record of each team's timeouts and inform referee #2
- E) Inform referee #1 if any team violates timeout standards. (Rule 19.4)
- F) Remind the referee about when the teams have to change sides

27.2.3 When the match concludes

- A) Finalized the score sheet and make sure it is accurate



- B) Have the team captains and the referees sign the score sheet
- C) Have all records of player misconduct and complaints on record
(Rule 16.1.7)

RULE SECTION 28: LINESMAN

28.1 LOCATION

28.1.1 For international matches, the linesman are positioned at the right hand side of referee #1 and referee #2 and stationed at the point where the bylines and the end lines meet, and 1-2 meters from the boundary line.

28.1.2 If 4 linesmen are used, then each person is positioned on each boundary line, and is 1-2 meters away from the line. (Rule 6)

28.2 RESPONSIBILITIES

28.2.1 Line judges are responsible for using a 30 x 30 cm flag for:
(Picture 8)

- A) Telling everyone if the ball has landed inbounds or out of bounds, and is responsible for that call
- B) Telling everyone if the ball has hit a player before landing out of bounds
- C) Telling everyone if the ball has crossed the net illegally, either through the ball crossing the plane of the net from beyond the boundary line or if it hits the antenna (Rule 14.1.1). The lineman is responsible for his/her line of the playing field
- D) Look and call for any foot fault during a serve
(Rule 16.5.1) The linesman tells referee #1 if the ball is inbounds or out.

RULE SECTION 29: OFFICIAL'S SIGNALS

29.1 REFEREE'S HAND SIGNALS

The referee will use hand signals to tell everyone the situation on the field 29.1.1 will use hand signals indicating the serving team

29.1.1 Will use and perform the hand signal, and keep it in that position and show the players and everyone so they can see the call.

29.1.2 If necessary, the referee will use hand signals to indicate player fault or misbehavior.



29.2 LINESMAN SIGNALS (Picture 8)

The linesman will use his flag to signal a call, and keep that position for a short time after the incident.

SECTION III - ENCLOSURES

Anexo 1 *Barreira*

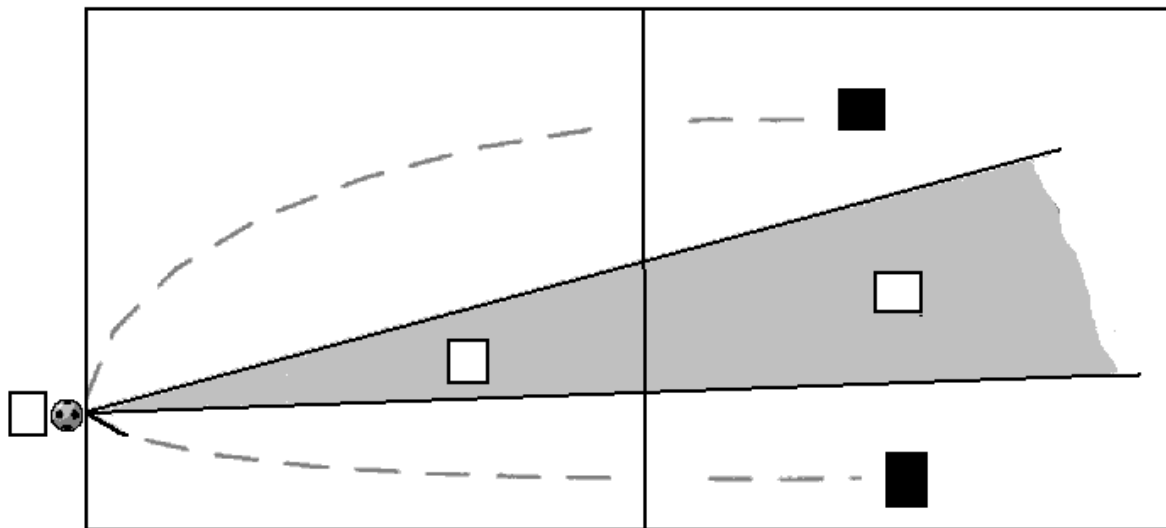

- *Normal*
- *Barreira*



Anexo 2

Bola Cruzando o Plano Vertical da Rede

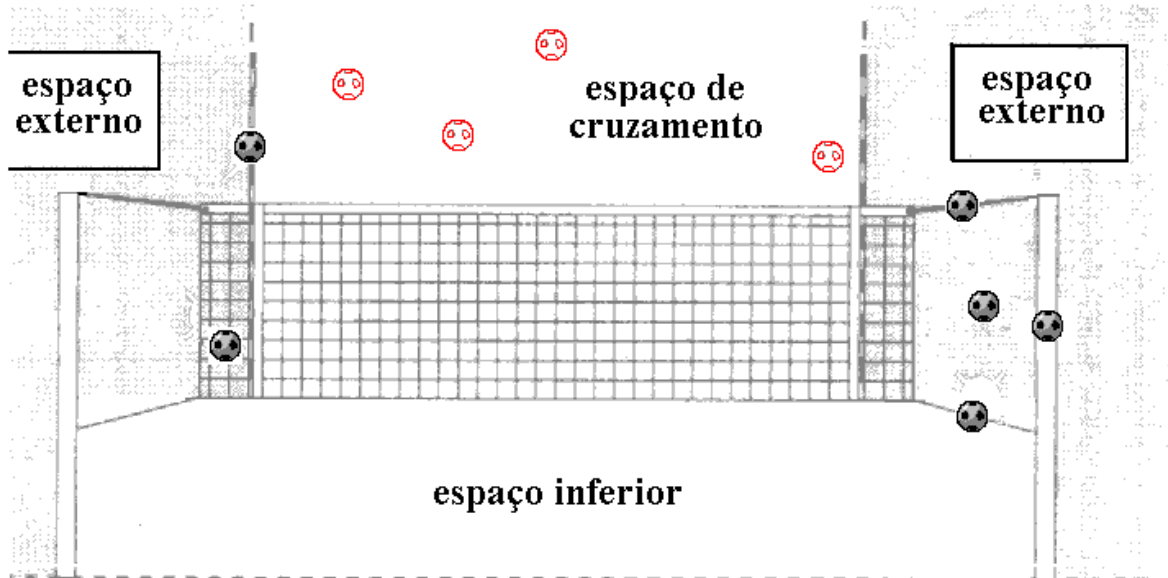

● falta



● passagem correta

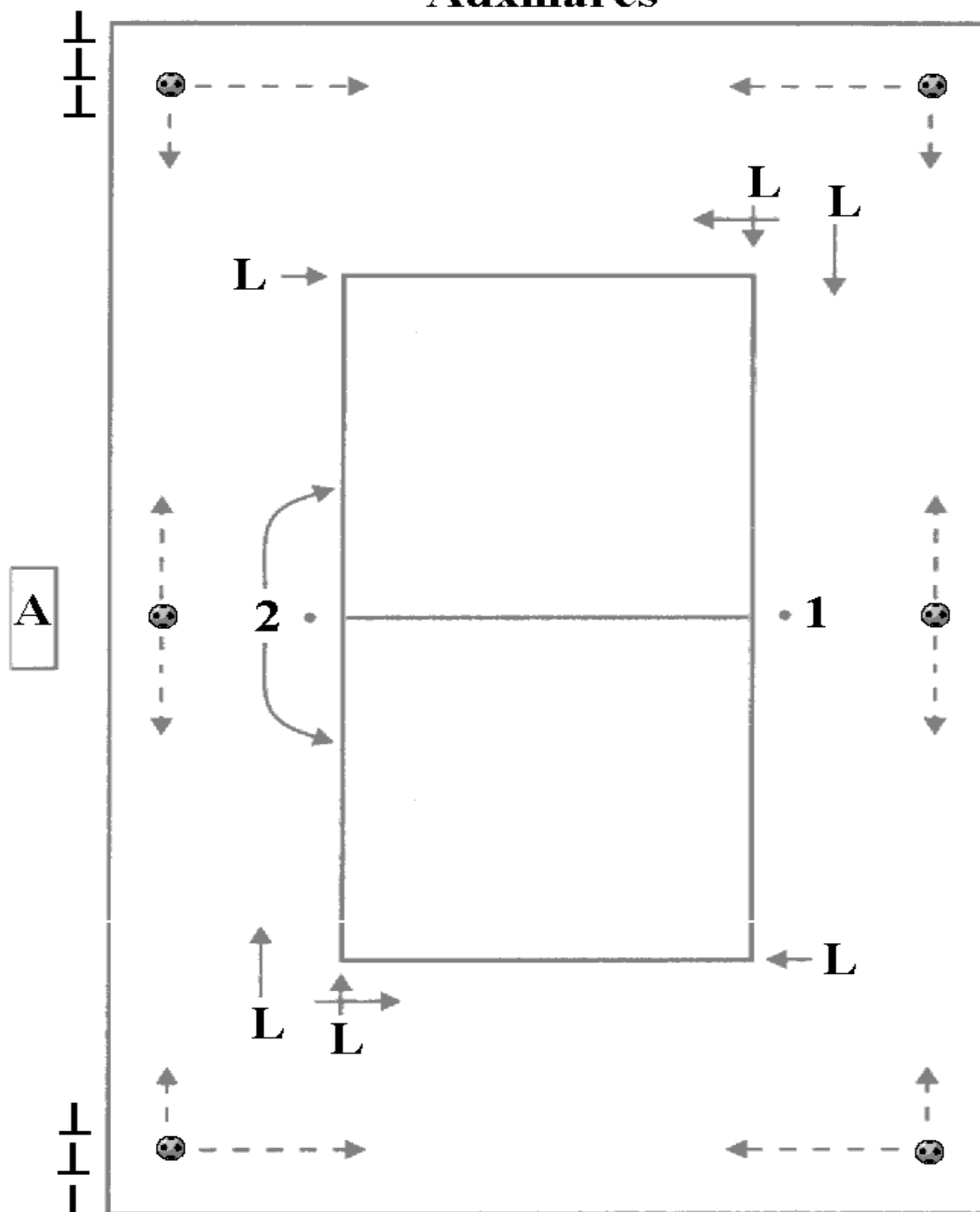

Anexo 3

Posicionamento da Equipe de Arbitragem e Auxiliares



- 1** primeiro árbitro
- 2** segundo árbitro
- A** apontador
- L** juiz de linha
-  boleiro
-  nivelador de areia



Anexo 4 Área de Jogo

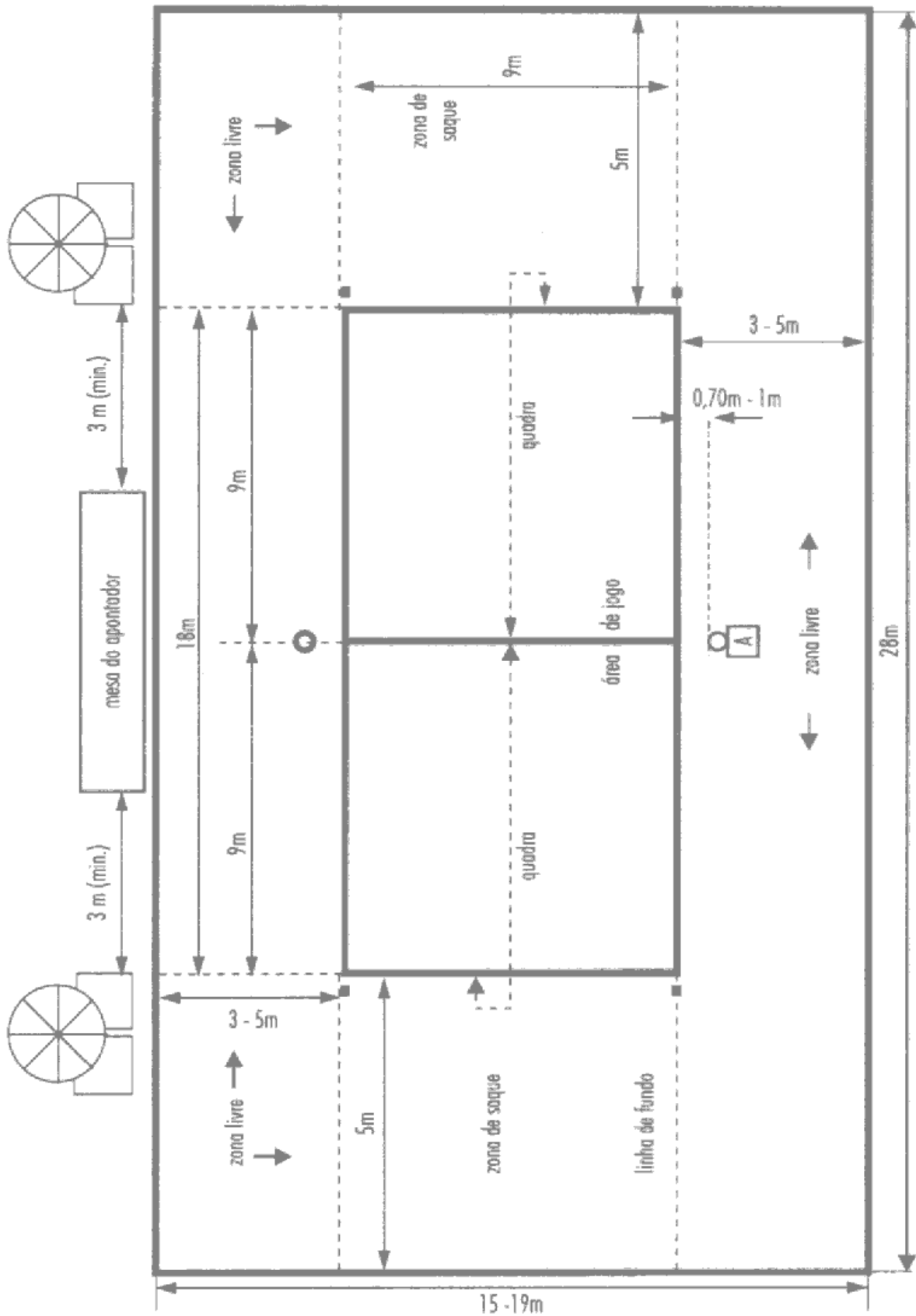





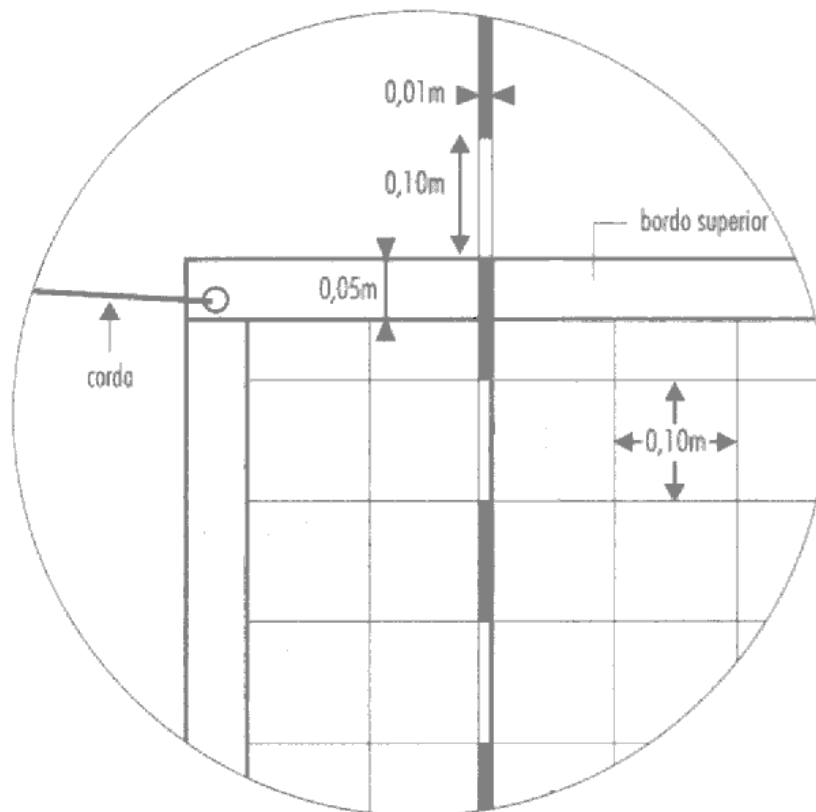
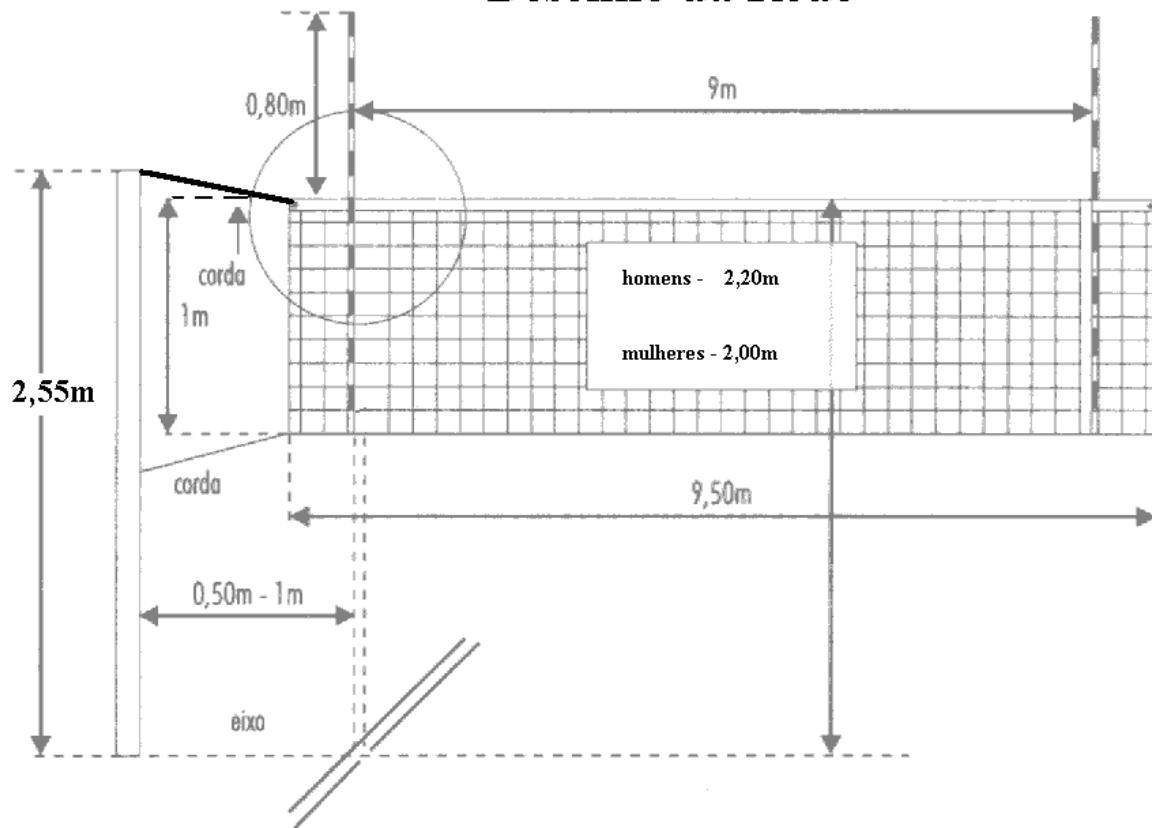

Anexo 5 Desenho da Rede



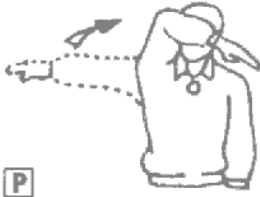

Anexo 6

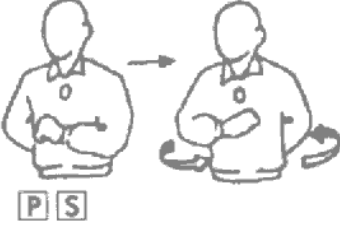



Sinalização Manual Oficial da Arbitragem - 1 a 5

Situações a serem indicadas	Primeiro árbitro P Segundo árbitro S	Sinais manuais a serem executados
1 Autorização para o saque R. 16.4	 P	Mover a mão para indicar a direção do saque.
2 Equipe a sacar R. 7.3 R. 24.2.3c	 P S	Estender o braço para o lado da equipe que vai sacar.
3 Troca de quadra R. 22.1	 P S	Colocar os braços na frente e nas costas e virá-los ao redor do corpo.
4 Tempo de descanso R. 19.3	 P S	Colocar a palma da mão sobre os dedos da outra, na posição vertical, formando um "T".
5 Advertência de retardamento R. 20.2.1 Penalidade por retardamento R. 22.2.2	 P	Apontar o pulso com o cartão amarelo (advertência) ou com o cartão vermelho (penalidade).



Anexo 6





Sinalização Manual Oficial da Arbitragem - 6 a 10

Situações a serem indicadas	Primeiro árbitro P Segundo árbitro S	Sinais manuais a serem executados
6 Advertência por conduta anti-esportiva R.23.2.1 ou penalidade R. 23.2.2		Mostrar cartão amarelo para advertência e vermelho para penalidade.
7 Expulsão R. 23.2.3		Mostrar os dois cartões juntos para a expulsão.
8 Desqualificação R. 23.2.4		Mostrar os dois cartões separadamente para a desqualificação.
9 Fim do set (ou do jogo) R. 7.1 R. 7.2		Cruzar os antebraços no peito, com as mãos abertas.
10 Bola presa no saque R. 16.5.4		Manter o braço estendido, a palma da mão voltada para cima.



Anexo 6

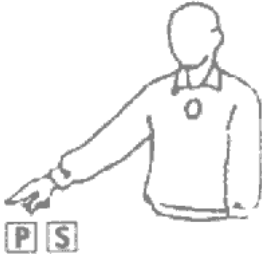



Sinalização Manual Oficial da Arbitragem - 11 a 15

Situações a serem indicadas	Primeiro árbitro P Segundo árbitro S	Sinais manuais a serem executados
11 Demora no saque R. 15.5.3	P 	Levantar os cinco dedos abertos.
12 Barreira R. 16.6	P S 	Levantar os dois braços verticalmente com as mãos espalmadas.
13 Bola tocada	P 	Friccionar a palma da mão com os dedos da outra, na posição vertical.
14 Bola "dentro" R. 11.3	P S 	Extender os braços e apontar o solo com os dedos.
15 Bola "fora" R. 11.4	P S 	Levantar os antebraços verticalmente, com as palmas das mãos viradas para o corpo.



Anexo 6



Sinalização Manual Oficial da Arbitragem - 16 a 20

Situações a serem indicadas	Primeiro árbitro P Segundo árbitro S	Sinais manuais a serem executados
16 Bola conduzida R. 13.5.d	P 	Levantar lentamente o antebraço com a palma da mão virada para cima.
17 Toque duplo R. 13.5.4	P S 	Levantar dois dedos abertos.
18 Quatro toques R. 13.5.1	P S 	Levantar quatro dedos abertos.
19 Rede tocada pela bola no saque ou por um jogador R. 15.4.3 R. 16.8.b	P S 	Tocar o bordo superior ou o lado da rede, de acordo com a falta.
20 Invasão por cima da rede R. 15.4.1	P 	Colocar a mão acima da rede com a palma da mão voltada para baixo.



Anexo 6











Sinalização Manual Oficial da Arbitragem - 21 a 23

Situações a serem indicadas	Primeiro árbitro P Segundo árbitro S	Sinais manuais a serem executados
21 Falta de ataque do jogador de defesa R. 17.2.3 R. 17.2.5 ou ao saque do adversário R. 17.2.4		Efetuar um movimento do alto para baixo com o antebraço, com a mão aberta.
22 Penetração na quadra do adversário R. 15.2 R. 14.1.3		Apontar para a linha central.
23 Falta dupla e repetição R. 12.2.3		Levantar os dois polegares na posição vertical.

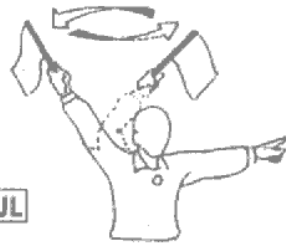

Anexo 6

Sinais Oficiais dos Fiscais de Linha com a Bandeira - 1 a 5

Situações a serem indicadas	Juiz de linha 	Sinais a serem executados
1 Bola "dentro" R. 11.3	 	Apontar para baixo com a bandeira.
2 Bola "fora" R. 11.4	 	Levantar a bandeira verticalmente.
3 Bola tocada R. 27.2.1.b	 	Levantar a bandeira e tocar, com a palma da mão, a ponta da bandeira.
4 Bola passando por fora do espaço de cruzamento ou falta do sacador por pisar na linha R. 11.4 R. 16.5.1	 	Agitar a bandeira por cima da cabeça e apontar a antena ou a linha de fundo.
5 Julgamento impossível	 	Levantar os dois antebraços e mãos e cruzar no peito.